

[NOTE]

1. Do not block ports (USB/Charger/Audio port)
2. Do not block holes (Microphone, Speaker, Vent)
3. Do not block the image features (Camera, Flash)
4. Do not obstruct NFC Antenna and wireless charging coil area with metal or other conductive material

Projection 	Scale	None	Model Galaxy S25+
		Size S	
	Unit	mm	
	Sheet No.	1/1	

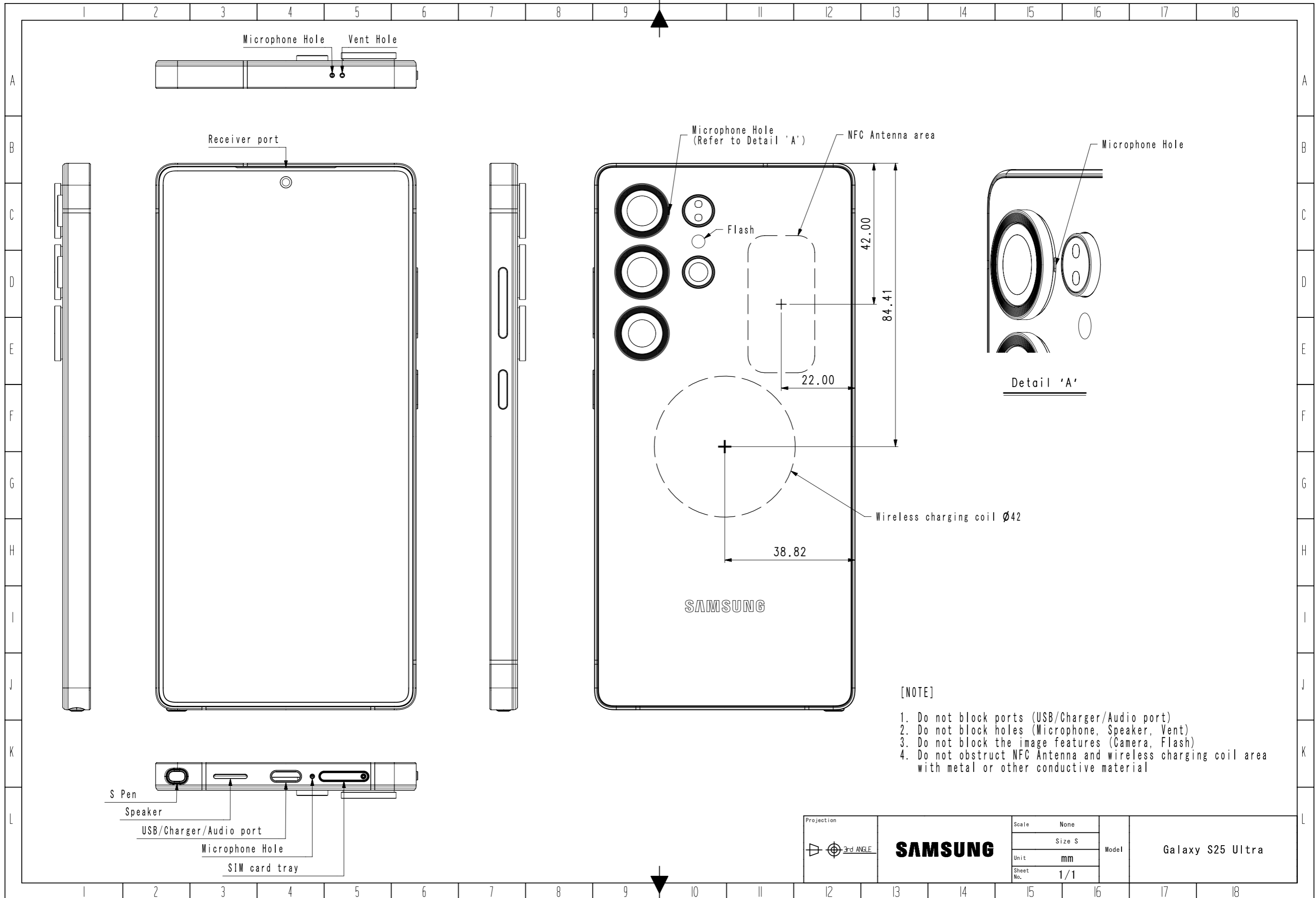

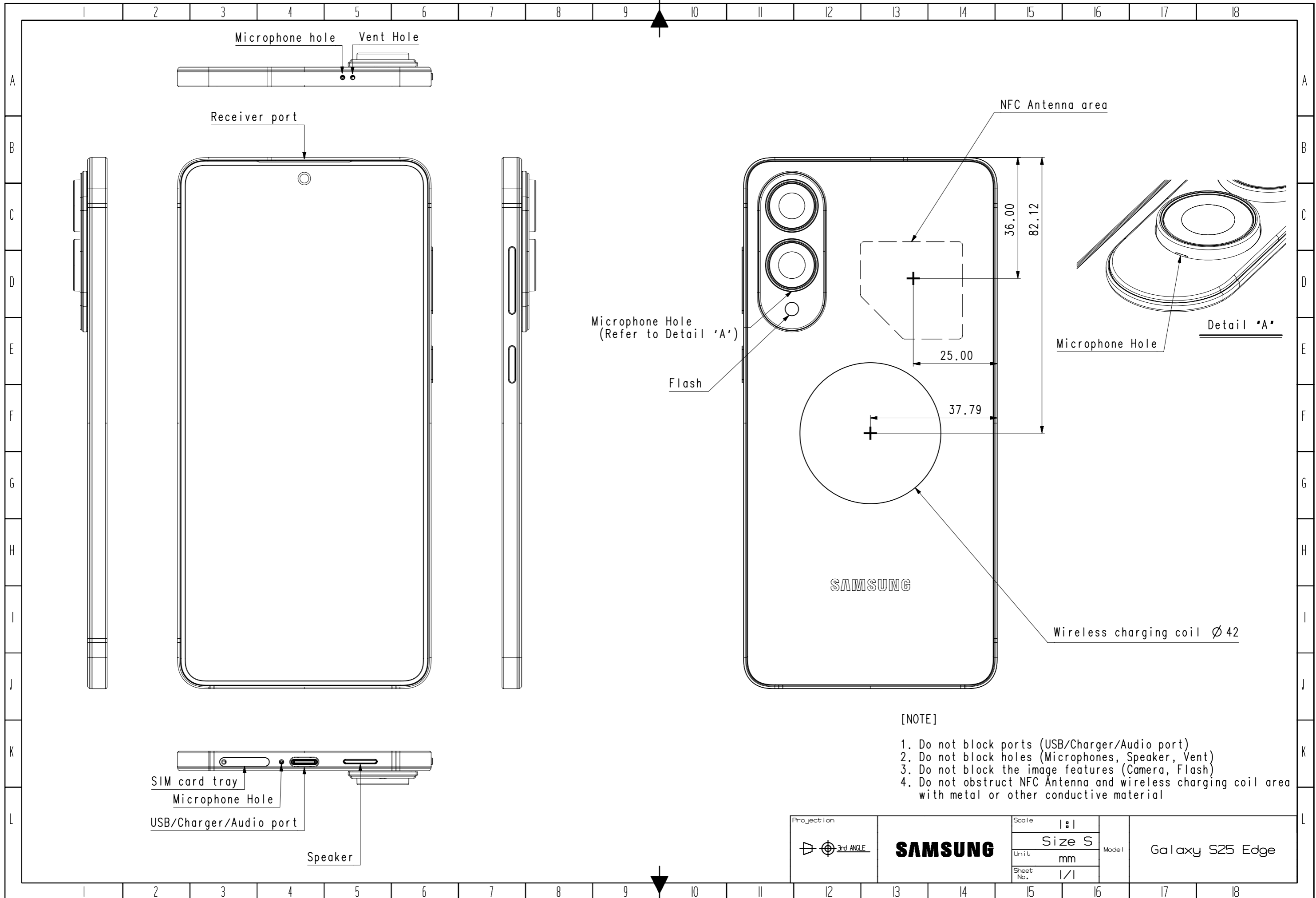

S25 Series reference design guide : Magnet Position & Cover Thickness

□ MPP Cover Guide #1

- ① Magnet Position ($d_{shift} : 3mm$)
 - Magnet center has been moved 3mm downward from the mobile phone center
- ② Cover Thickness
 - Cover thickness $d_{z,1} = 2.15T$
 - An air gap (d_{air}) exists between the mobile phone and the cover.
 - Total thickness = $d_{z,1} + d_{air}(=0.05T) = 2.2 T$
- ③ Thickness of Magnet + Cover Surface ($d_{z,2} : \max 0.8T$)
 - $d_{z,2}$ is an important parameter affecting tensile force, and it is managed to stay within 0.8T, including tolerance.
- ④ Tilt Angle of Magnet Shield Slit (θ_{tilt})
 - This angle represents the angle between 12o' clock reference direction and the center of magnet shield slit.
 - θ_{tilt} is utilized by the mobile device for detecting the magnet cover.

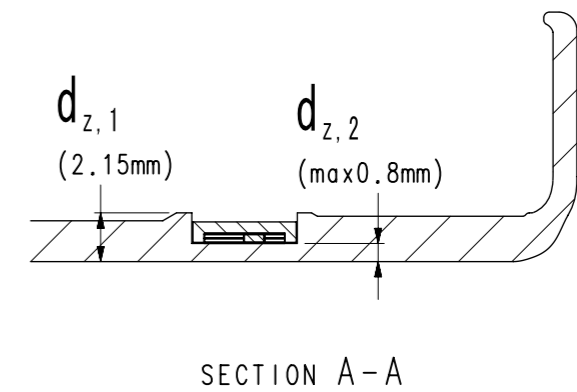
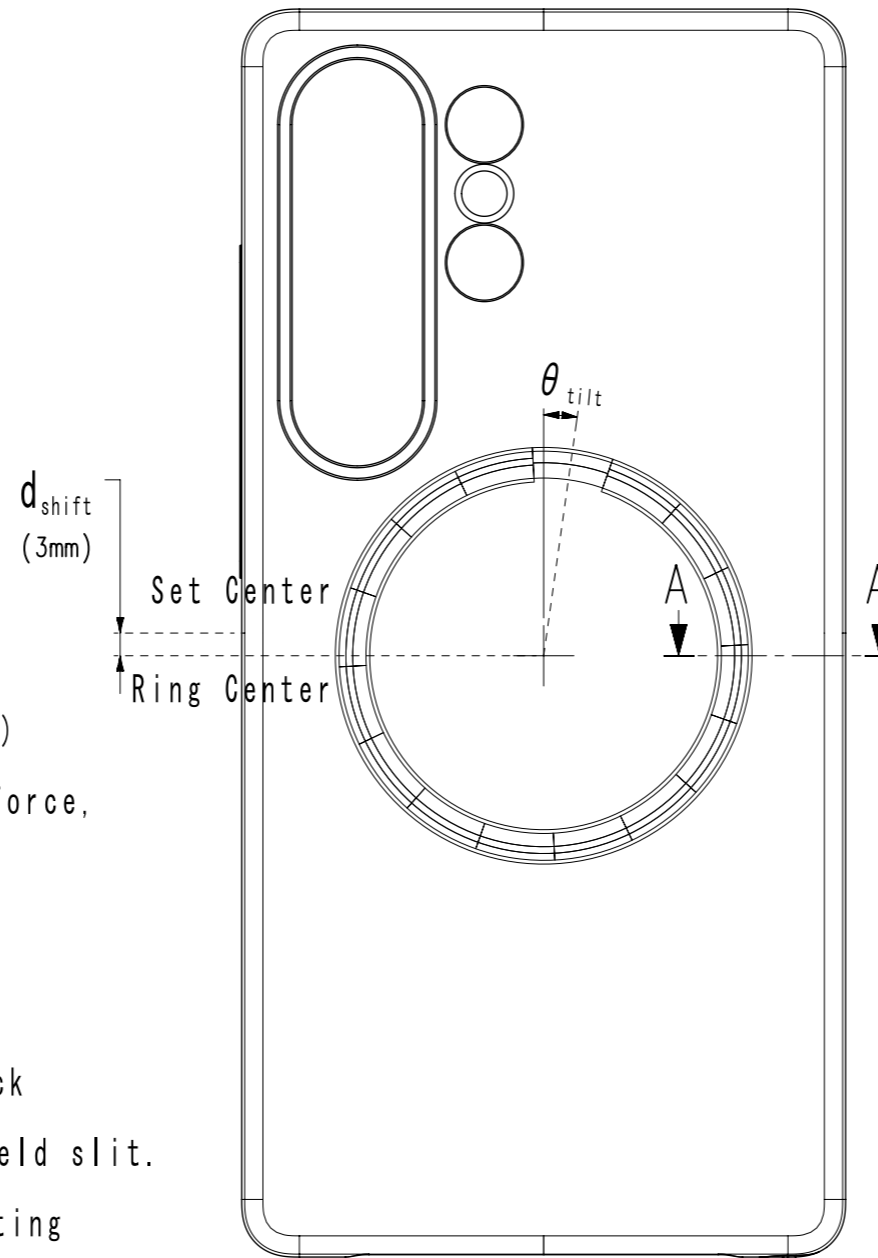

□ Key Dimension

	S25 Ultra	S25 Plus	S25	S25 Edge
θ_{tilt} (Tol ± 0.1)	8°	0°	10°	0°
d_{shift}	3mm	←	←	←
$d_{z,1}$	2.15mm	←	←	←
$d_{z,2}$	max 0.8mm (Tol $-0.1mm$)	←	←	←
d_{air}	0.05mm	←	←	←

- ※ Air gap (d_{air}) between SET + Cover : 0.05 mm
- ※ Total thickness = $d_{z,1} + d_{air} : 2.2 mm$
- ※ Tolerance : $\pm 0.05mm$, unless otherwise specified

Projection 	SAMSUNG	Scale	None	Model Galaxy S25 Series
		Size	S	
		Unit	mm	
		Sheet No.	1/1	

S25 Series reference design guide : Magnet & Shield

Magnet Array (16 pieces)

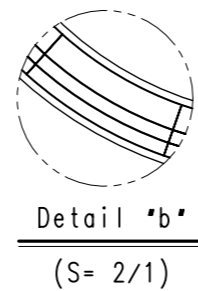
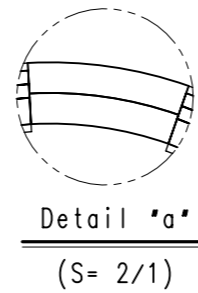
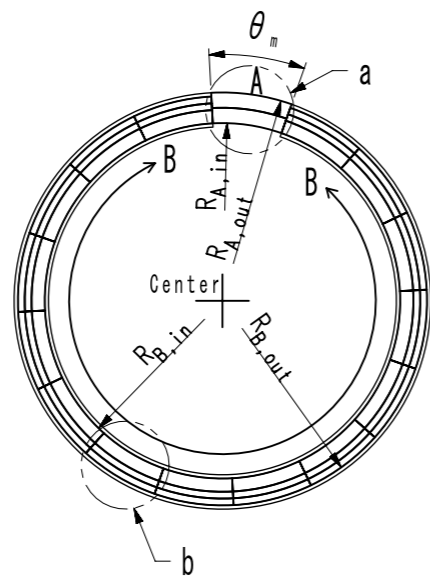
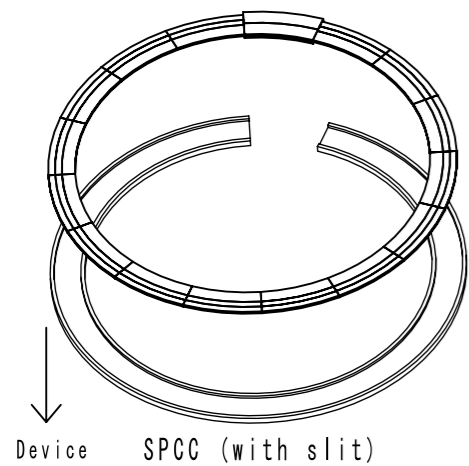

※ 'A' Magnet Magnetization Pattern

① S25U, S25

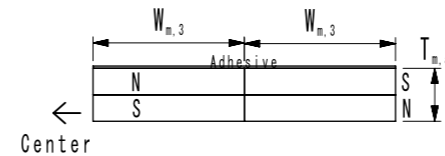

② S25+, S25 Edge

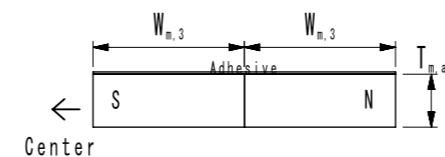

※ 'B' Magnet Magnetization Pattern

(Identical for all S25 series)

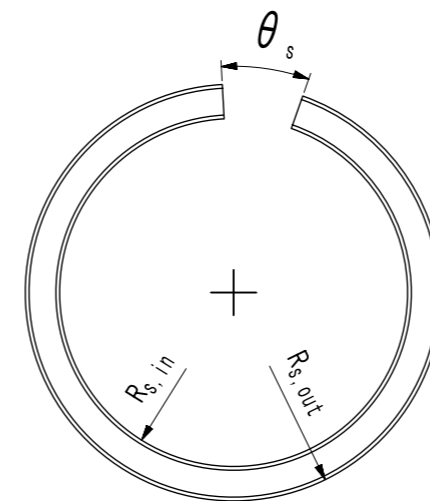
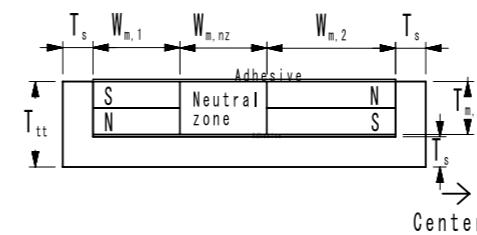

※ Magnet shield

□ Key Dimension (Magnet)

	S25U, S25	S25+, S25 Edge
Magnet Grade	A : N35SH B : N45SH	A : N45SH B : N45SH
Surface Finishing	A : Epoxy Coating B : Nickel Plating	
θ_m (Tol. $\pm 1^\circ$)	22.5°	
$R_{A,in} / R_{A,out}$	23.5 / 27.55 mm	
$R_{B,in} / R_{B,out}$	23.5 / 27.05 mm	
$W_{m,1}, W_{m,nz}$	0.9 mm	
$W_{m,2}$	1.75 mm	
$W_{m,3}$	2.025 mm	
Magnet Width	A : $W_{m,3} + W_{m,3}$ A : 4.05 mm B : $W_{m,1} + W_{m,nz} + W_{m,2}$ B : 3.55 mm	
T_{adh} (Tol : $\pm 0.01mm$)	0.05 mm	
$T_{m,A}$	0.7 mm	
$T_{m,B}$	0.35 mm	
T_{adh} (Tol : $\pm 0.01mm$)	0.05 mm	
T_{tt}	0.95 mm	

□ Key Dimension (Magnet Shield)

Material	SPCC
Surface Finishing	Nickel Plating
θ_s (Tol : $\pm 1^\circ$)	22.5°
$R_{s,in}$	23.0 mm
$R_{s,out}$	27.55 mm
Magnet Shield Width ($R_{s,out} - R_{s,in}$)	4.55 mm
T_s	0.5 mm

※ Tolerance : $\pm 0.05mm$, unless otherwise specified

□ MPP Cover Guide #2

- ① Inner / Outer Radius of Magnet ($R_{A,in}$, $R_{A,out}$, $R_{B,in}$, $R_{B,out}$)
- Magnet (A) and (B) has different dimensions for their respective purposes.
- ② Magnetization and Neutral zone Area ($W_{m,1}$, $W_{m,2}$, $W_{m,3}$, $W_{m,nz}$)
- The Neutral zone refers to the unmagnetized region within a single magnet.
- ③ Magnet Thickness ($T_{m,A}$: 0.7T / $T_{m,B}$: 0.35T)
- ④ Magnet Shield Thickness and Material (T_s : 0.5T / SPCC)
- The 'U-shaped' magnet shield is made from a single piece of SPCC.
- ⑤ Slit Width of Magnet Shield (θ_s : 22.5°)
- Magnet A is not shielded by SPCC, and a 22.5° SPCC slit is provided for this purpose.
- ⑥ Total Thickness (T_{tt} : 0.95T)
- $T_{tt} = T_{adh} + T_{m,B} + T_s + T_{adh} = 0.95T$

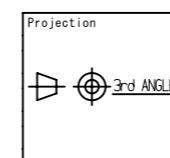

SAMSUNG

Scale None
Size S
Unit mm
Sheet No. 1/1

Model

Galaxy S25 Series